

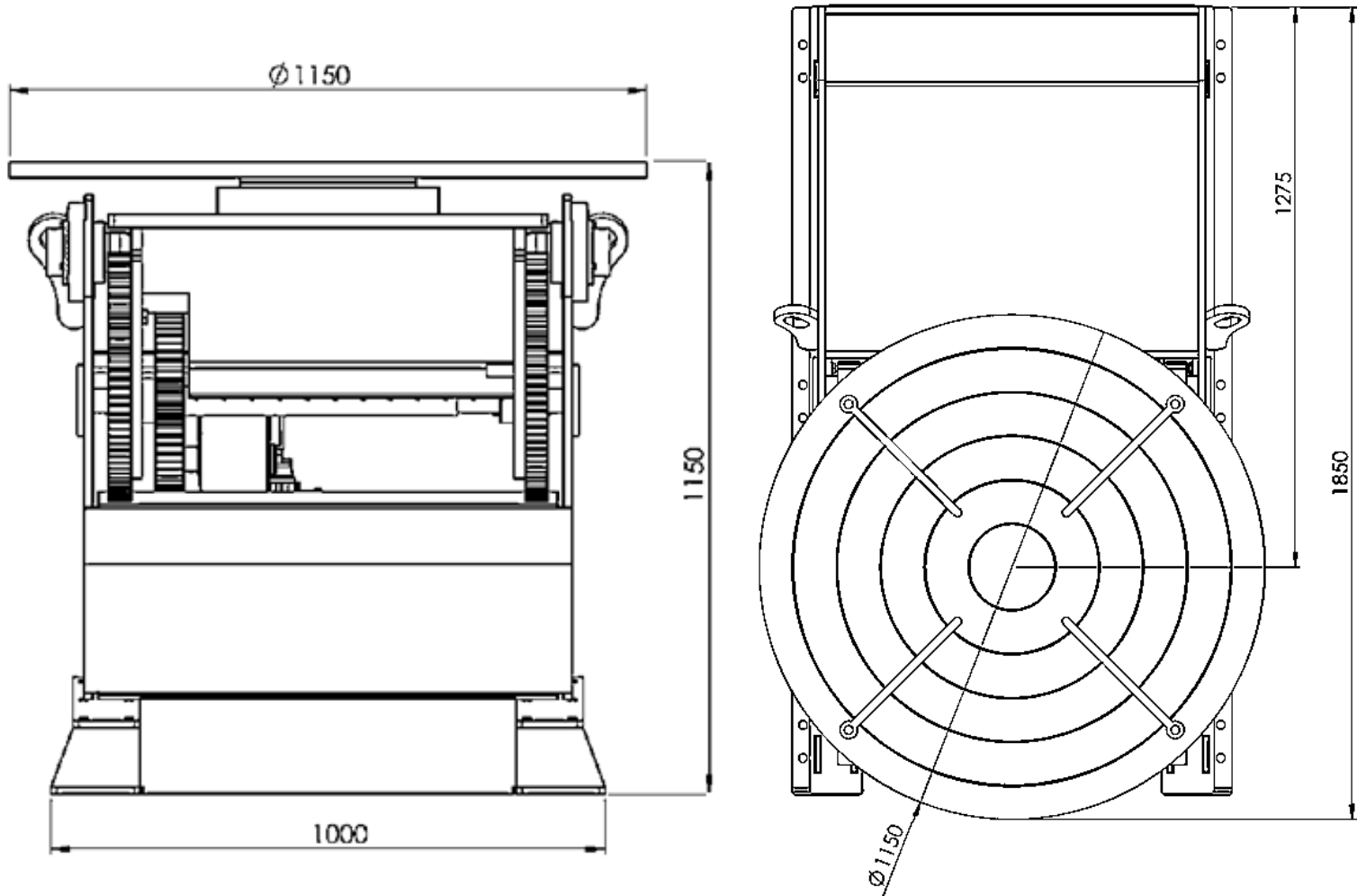

# Technical Specifications – WPOZ 1000



Max. Load (N)	10000
Axis Eccentricity	150mm for Rotation and Tilting
Rotation Speed (rpm/min)	Min 0,15 – Max 1,5 @ 5 Hz – 50 Hz Range
Rotation Torque (kg.m)	150
Rotation Motor	1 x 0,75 Kw AC Motor
Tilting Angle	120°
Tilting Speed from 0 to 120	60 second
Tilting Torque (kg.m)	300
Tilting Motor	1 x 0,55 Kw AC Motor
Driver	Yaskawa 2.2 Kw / 1.5 Kw
Face Plate Diameter	1150 mm
Fixing Slots	4 T-Slots / M16 (it can be M18 or anyelse)
Control Device	Standing Control Panel
Incoming Supply	380/400V, 3Ph, 50Hz @ 5 – 50 Hz
Applicable Optional	Hand Pendant & Foot Pedal
Colour	RAL6025 GREEN/Texture Painting
Welding Torch Holder	No
Shipping Dimension & Weight	Width 1380mm x Length 2100mm x Height 1500mm / 1450 Kg